

PRODUCT UPDATE...

Feb. 2nd, 2009

WIRE ROPE GAUGE

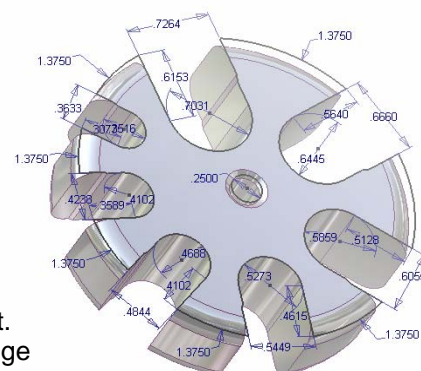

History

Between the year 2000 and 2003, an industry need was recognized for a convenient hand held tool for field use to assist with initial rope wear assessment. Lustre Products responded with the introduction of part # **ATL096** -a “no-go” gauge designed to measure the reduced diameter size of ropes, in accordance to **A17.1-1996**

2003- Marked a turning point where the industry recognized an inconsistent (proportional / percentage) amount of diameter reduction was permissible and varied between diameters (from 5.3% up to 8.3%). A standardized 6.25% reduction was proposed & at the same time the industry recognized and placed new diameter reduction criteria on ropes with ROUGE characteristics of 3.125% diameter reduction. These NEW standardized diameter reductions were introduced as part of the new code revisions - **A17.6** As an acknowledgment of the proposed and in anticipation of the adoption of A17.6 the industry embraced the use of the next generation of wire rope wear gauges (ATL001 & ATL00M), complete with rouge criteria.

2009- Presents a lesson in patience. Although the specific revision for steel ropes, as noted above from A17.1 to the new proposed A17.6 has been ready to go since 2003, the final approvals have been yet again delayed. As fiber and synthetic rope are introduced and changed – the code committee is trying to adapt and publish the A17.6 to be as inclusive as possible of all rope types and construction. These many, many delays have been unforeseen and equally frustrating for the entire industry.

What's Next ... – The NEW code (A17.6) is not yet a reality. Once approvals are finalized and adopted, ASME will reference A17.6 for these code changes. When that happens some states and other jurisdictions will automatically and immediately adopt the changes, while others will adopt on a jurisdiction by jurisdiction basis – this individual adoption process *could* span upwards of 10 to 15 years.

Now What ? – In consideration of the entire industry, including most inspectors, using and referencing the incoming A17.6 code, and in recognition of the unforeseen delays in the adoption, we propose :

- The re-introduction of the **ATL096 (A17.1)** gauge as a *current* code compliant option for your customers.

Options...

- ATL096** – (A17.1) – Imperial wire rope gauge (7 slot) – **Black color** (3/4, 11/16, 5/8, 9/16, 1/2, 7/16, 3/8)
- ATL001** – (A17.6) - Imperial wire rope gauge (7 slot) with ROUGE – **Red color** (3/4, 11/16, 5/8, 9/16, 1/2, 7/16, 3/8)
- ATL00M** – (A17.6) - Metric wire rope gauge (7 slot) with ROUGE – **Blue color** (22, 19, 16, 13, 11, 10, 8 mm)
- ATL00KM** – (A17.6) - Metric wire rope gauge (8 slot) with ROUGE – **Blue color** (19, 16, 13, 11, 10, 9.5, 8, 6 mm)

Looking Ahead – Educating customers and advising of the current code adoption delays as well as the widely accepted understanding that A17.6 will become reality.... Will allow customers to make a decision to equip themselves with the tools for today and for the future. We have a responsibility to educate and provide gauges which meet current A17.1 codes, as much as we have a responsibility to assist proactively in ensuring our customers are adapting to and understanding the incoming changes with the new ASME A17.6 code.